

Patent: See www.LibertyPumps.com/LEP/patents

Model Number	LGH153B	LGH159B	LGV153B	LGV159B
HP	15	15	15	15
Volts	200/230*	380/400/415	200/230*	380/400/415
Phase	3	3	3	3
Hz	50	50	50	50
RPM	2875	2875	2875	2875
FLA	36.4/33.7	18.9/18.2/17.6	32.8/30.7	17.0/16.2/16.0
LRA	314	130	314	130
kW Input @ FLA	11.6	11.4	10.5	10.0
NEMA Code	B	B	B	B
Service Factor	1	1	1	1
Power Factor @ FL	0.86	0.89	0.85	0.88
KVA Code	J	H	J	H
Std Impeller Diameter (mm [inches])	211 [8.3]	211 [8.3]	193 [7.6]	193 [7.6]
Shut-Off Head w/Std Impeller (m)	54.0	54.0	45.0	45.0
Min Head w/Std Impeller (m)	30.5	30.5	15.2	15.2
Max Flow @ Min Head (m ³ /hr)	33.5	33.5	52	52
Power Cord Type & Diameter	Type W, 26 mm	SOOW, 19 mm	Type W, 26 mm	SOOW, 19 mm

* System voltages: 208 and 240 volts with utilization voltages: 200 and 230 volts. These pumps are able to be rewired to 380/400/415 volts in the field.

Motor Insulation Class	H 180°C
Impeller Type	Semi-Open
Impeller Material	Stainless Steel
Control Cord Type & Diameter	18/5 SOOW, 10 mm
Power Cord Length (Options)	10.7, 15.2, 30.5 meters [35, 50, 100 feet]
Permanent Cords	Standard
Heavy-duty Quick-connect Cords	Optional
Upper (Inner) Seal Material	Graphite Impregnated Carbon - Rotating Silicon Carbide - Stationary Viton Elastomers
Lower (Outer) Seal Material (Standard)	Silicon Carbide on Silicon Carbide Viton Elastomers
Lower (Outer) Seal Material (Optional)	Tungsten Carbide on Tungsten Carbide Viton Elastomers
Max Water Temp for Continuous Duty	40°C
Min Fluid Level for Continuous Operation	Motor Housing Fully Submerged
Fluid pH Range	4–10

Starts Per Hour	30
Shaft Material	416 Stainless Steel
Fastener Material	316 Stainless Steel
O-Ring Elastomers	Buna-N
Upper Bearing	Single Row Deep Groove
Lower Bearing	Double Row Angular Contact
Oil Type	ISO VG10 Turbine Oil
Max Submersion Depth	23 meters [75 feet]
Discharge	Horizontal 3 in 150# ANSI
Protective External Finish	Epoxy Powder Coat
Seal Fail Detection	Dual Probe - 2 Wire with Resistor 200K ohm Resistance
Thermal Protection	3 Hermetically Sealed Thermostats 125°C Opening Temperature 105°C Closing Temperature 3A @ 120 VAC, 1A @ 240 VAC
Volute Material	Class 30 Cast Iron
Pump Weight	400 lbs (approx.)
Cuts Per Minute	Over 400,000
Cutter Material	Hardened 440 Stainless Steel
Standards	Tested to CSA and UL® Standards CAN/CSA C22.2 No. 108-14 ANSI/UL 778 6th Ed

Specifications are subject to change without notice.

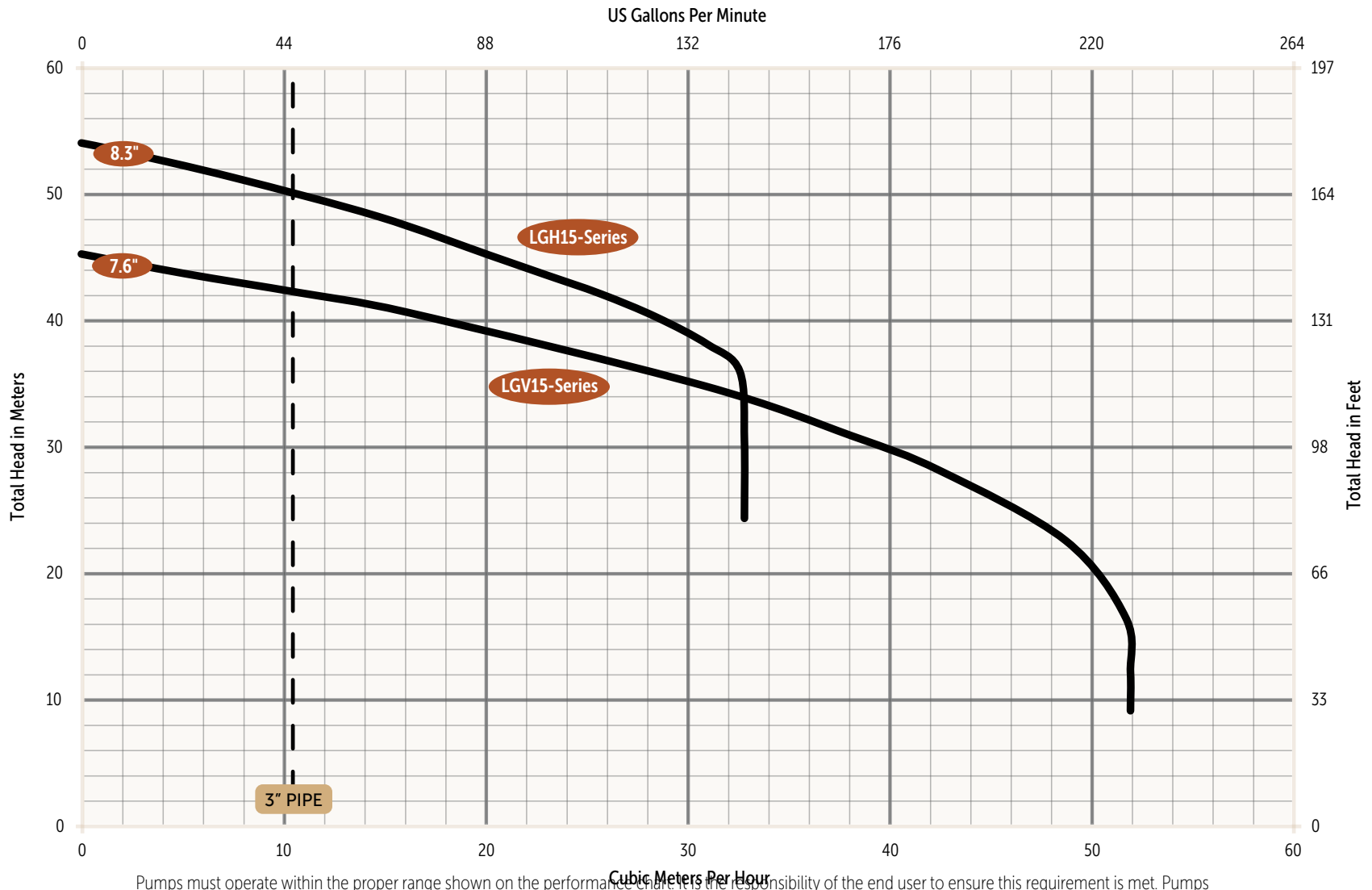

Pumps must operate within the proper range shown on the performance chart. It is the responsibility of the end user to ensure this requirement is met. Pumps operating outside the recommended range are prone to damage, excessive vibration, cavitation, poor efficiency, and may exceed nameplate amperage.

Specifications are subject to change without notice.

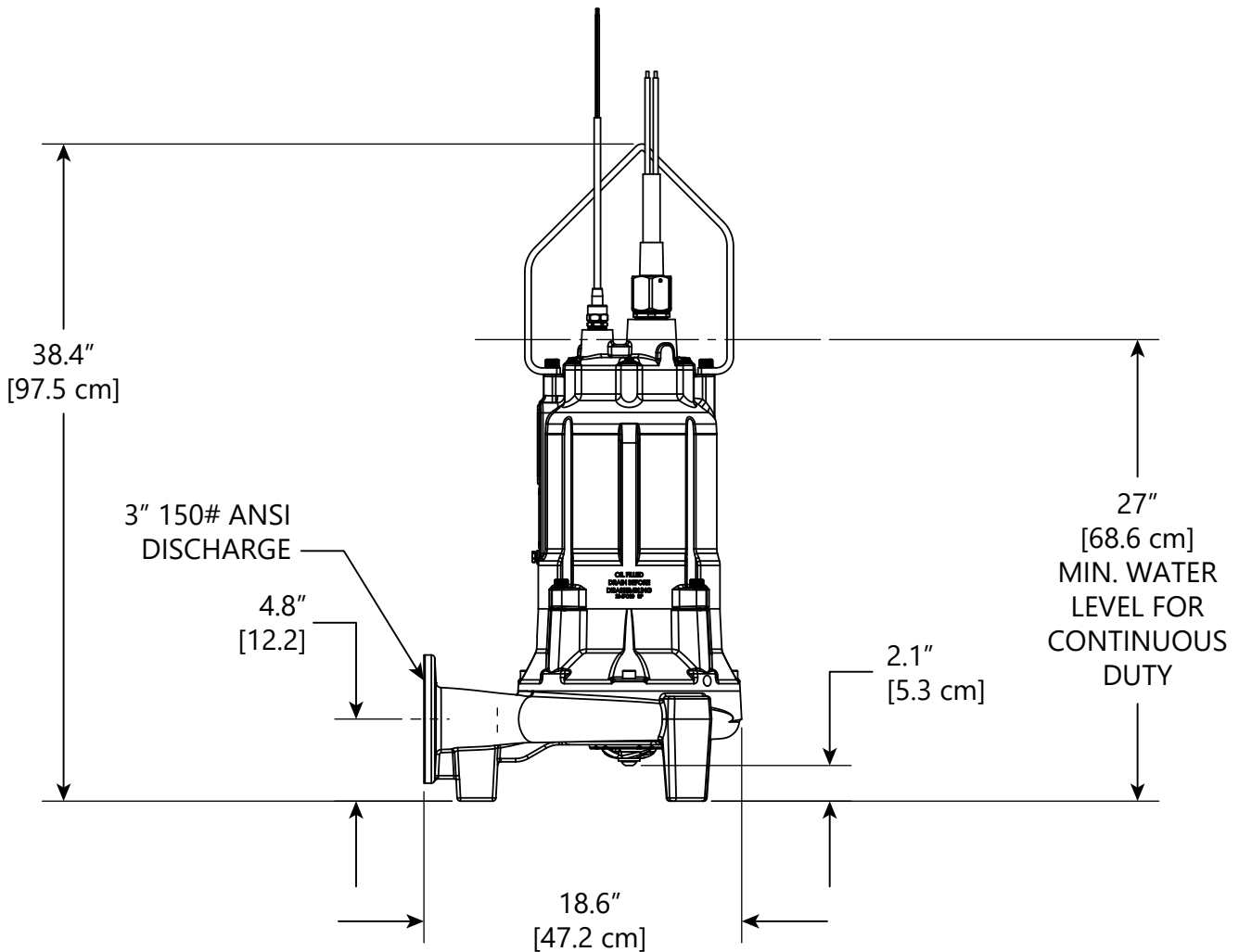
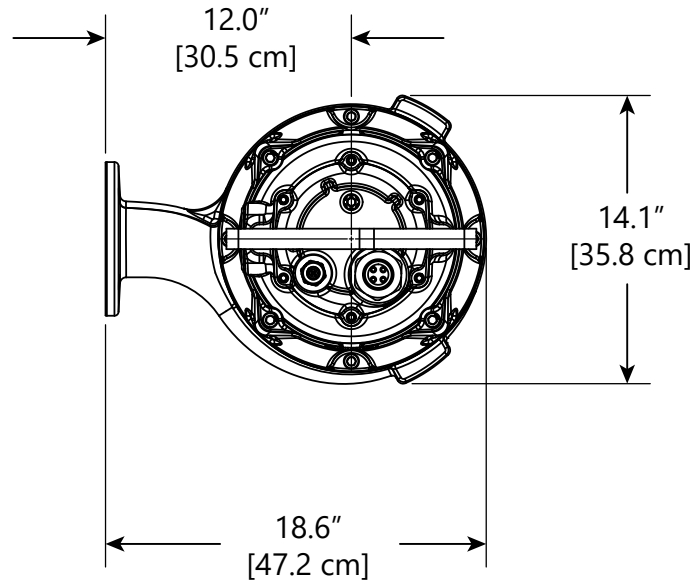

Specifications are subject to change without notice.

GENERAL

The contractor shall provide labor, material, equipment, and incidentals required to provide _____ (QTY) sewage grinder pumps as specified herein. The pump models covered in this specification are LGH153B, LGH159B high head and LGV153B, LGV159B high volume grinder pumps. The pump furnished for this application shall be model _____ as manufactured by Liberty Pumps.

OPERATING CONDITIONS

Each submersible pump shall be rated at 15 hp, _____ Volts, 3-phase, 50 Hz, 2875 RPM. The unit shall produce _____ m³/hr at _____ meters of total dynamic head.

The submersible pump shall be capable of handling residential and commercial sewage and grinding it to a fine slurry, enabling it to be pumped over long distances. The LGH15-Series submersible pump shall have a shut-off head of 76.2 meters and a max flow of 32.2 m³/hr @ 33.5 meters of total dynamic head. The LGV15-Series submersible pump shall have a shut-off head of 61 meters and a max flow of 56.3 m³/hr @ 24.4 meters of total dynamic head.

CONSTRUCTION

Each centrifugal sewage grinder pump shall be equal to the Certified LGH15/LGV15-Series pumps as manufactured by Liberty Pumps, Bergen NY. The casting enclosing the motor shall be constructed of class 30 cast iron. The motor housing shall be oil-filled to dissipate heat. Air-filled motors shall not be considered equal since they do not properly dissipate heat from the motor. Mating parts shall be machined and sealed with a Buna-N O-ring. All fasteners exposed to the process fluid shall be stainless steel. The motor shall be protected on the top side with a sealed cast iron cord entry plate, which is potted to prevent water from entering through the cord. The motor shall be protected on the lower side with a dual mechanical seal arrangement and an oil-filled intermediate chamber. The upper (inner) seal shall be a two-piece mechanical seal with a Graphite Impregnated Carbon rotating and a silicon carbide stationary face. The lower (outer) seal shall be a two-piece mechanical seal with silicon carbide faces. The upper and lower bearings shall be sized to properly withstand radial and thrust loads produced throughout the full operating range of the pump.

POWER AND CONTROL CORD

The submersible pump shall be supplied with 10.7, 15.2, 30.5 meters of a multi-conductor cord of type W for the LGH153B and LGV153B models, and type SOOW for the LGH159B and LGV159B models. These type W & SOOW power cords carry a voltage rating of 600 V, a temperature rating of 90°C, have oil-resistant insulation, are water- and weather-resistant, UL listed, and CSA approved.

The power cord shall be sized for the rated full load amps of the pump for continuous duty in accordance with the NEC®. A separate type SOOW control cord of equal length shall also exit the pump. The cord entries to the pump shall be protected via two sealing methods. The cords first pass through a Buna-N compression grommet that seals against the outer jacket of the cord. The Buna-N grommet also doubles as a strain relief. Each individual conductor then continues into a chamber that is filled with epoxy potting compound. The epoxy potting compound seals each individual conductor and protects against any intrusion of liquid into the motor cavity in the event of wicking. The power and control cord leads shall be connected to the motor leads via a terminal block.

HEAVY-DUTY QUICK-CONNECT CORD

(OPTIONAL)

Optional Heavy-duty Quick-connect cord shall offer quick cord replacement without the need to send the entire pump to an authorized repair facility. This shall also allow for pump maintenance without disturbing electrical boxes or control panels. A terminal block shall be used for internal wire connections.

MOTOR

The motor shall be oil-filled, inverter duty, Class H insulated, NEMA A design, and rated for continuous duty. Since air-filled motors are not capable of dissipating heat efficiently, they shall not be considered equal. The mid chamber design utilizing **MidTherm™ Cooling** technology shall allow for oil in the motor chamber to reject heat to the pumped media and provide cooling to the motor. This motor design shall provide significantly reduced operating temperatures. Pumps requiring an auxiliary cooling means shall not be considered equal.

The motor shall be constructed to meet IE3 Premium Efficiency standards in accordance with NEMA MG1. The copper stator windings shall be insulated with moisture-resistant Class H insulation materials, rated for 180°C per NEMA MG1 1.66. The maximum continuous temperature of pumped liquids shall be 40°C. The winding operating temperature at rated horsepower and service factor shall be a maximum of 125°C @ 40°C ambient.

Motor shall have UL approved thermostats mounted directly on the stator windings. Motor shall have three thermostats, one on each phase. The thermostat leads of the control cord shall be connected to a motor control relay in the control panel.

Motor service factor shall be 1.0 under normal conditions and 1.0 when operated on a Variable Frequency Drive (VFD) per MG1 standard. Motor shall have a voltage tolerance of ±10% from nominal. Motor shall meet the requirements of NEMA MG1 Part 30 and 31 for operation on Pulse Width Modulation type VFD with inverter duty rated magnet wire and insulation. Motor shall be capable of handling up to 30 evenly spaced starts per hour without overheating.

BEARINGS AND SHAFT

The shaft shall be supported by two ball bearings. The top bearing shall be a deep groove radial contact ball bearing and the lower bearing shall be a double row angular contact ball bearing designed to handle the radial and axial forces incurred by pumping. The lower bearing shall be positively retained by a threaded bearing retaining nut, which eliminates any axial movement or rotation of the outer bearing race. Both bearings shall be permanently lubricated by the oil that fills the motor housing. Pump designs requiring scheduled bearing maintenance shall not be considered equal. Pumps with single row lower bearings or sleeve bearings shall not be considered equal. The bearing system shall be sized to provide a minimum of 100,000 hours B10 bearing life throughout the operating range of the pump. Pumps that only provide a 50,000 hour B10 bearing life shall not be considered equal.

The motor shaft shall be made of 416 stainless steel. The motor shaft shall be constructed from a single piece of stainless steel. Spin welded shafts shall not be considered equal. The shaft shall be designed to withstand the maximum torque and radial loads present during start-up and normal operation. Shafts of carbon steel or chrome-plated shafts shall not be considered equal.

SEALS

The pump shall have two shaft seals separated by an oil chamber. Pumps utilizing single seal technology shall not be considered equal. A leak detection probe shall be positioned in the oil chamber and shall allow for continuous monitoring for lower (outer) seal failure. The lower seal shall be a two-piece design that is easily serviceable. Shaft seals shall not require scheduled maintenance. The upper (inner) seal shall be Graphite Impregnated Carbon on silicon carbide and the lower seal shall be silicon carbide on silicon carbide. Both seals shall include stainless steel housings and Viton elastomers. Lower seals shall be optionally available in tungsten carbide.

CUTTER MECHANISM

The cutter and plate shall consist of hardened 440 stainless steel with a Rockwell C hardness of 55-60. The stationary cutter plate shall have specially designed orifices through it, which enable the slurry to flow through the pump housing at an equalized pressure and velocity. The stationary cutter plate shall feature patented V-Slice® Cutter Technology. This superior cutting system consists of V shapes to maximize cutting action and arc shape exclusion slots to outwardly eject debris from under the rotary cutter. The rotary cutter shall have four blades and be designed with a recessed area behind the cutting edge to prevent the accumulation and binding of any material between rotary cutter and the stationary cutter plate. The cutter shall be capable of over 400,000 cuts per minute. The cutting system shall incorporate close tolerances for optimum performance. Ring or radial cutters, or those that grind on the outside circumference of shall not be considered equal.

IMPELLER

The impeller shall be stainless steel. The impeller shall be dynamically balanced, keyed and bolted onto the motor shaft.

SHAFT GROUNDING BRUSH

The pump shall be equipped with a shaft grounding brush. Pumps not utilizing a current mitigation technology shall not be considered equal.

CONTROL PANEL

All LGH15/LGV15-Series pumps require a control panel. The control panel shall be equipped with circuit breakers and adjustable overload devices to protect against excess current or electrical problems. This device shall be sized appropriately for the pump model(s) being controlled.

The control panel shall include thermal overload relay(s) that shall shut down the pump in the event the thermostats in the motor open. Thermostats are designed to open at 125°C.

The control panel shall include a seal fail monitoring device that shall indicate a primary seal failure. The seal fail monitoring device shall be capable of monitoring the resistance of the seal failure probe in the pump. The sensitivity of the seal fail monitoring device shall be adjustable from approximately 1KΩ to at least 250kΩ.

QUALITY CONTROL

The pump shall be manufactured in an ISO® 9001 certified facility. Manufactured in the USA with US and global components.

SUPPORT

The pump shall have cast iron support legs, enabling it to be a freestanding unit. The legs shall be high enough to allow solids and long stringy debris to enter the pump inlet.

PROTECTIVE FINISH

The exterior of the casting shall be protected with corrosion-resistant baked-on epoxy powder coat.

TESTING

The pump shall have a ground continuity check and undergo a hi-pot test for electrical integrity, moisture content, and insulation defects. The motor housing and mid chamber shall be pressurized, and an air leak decay test performed to ensure integrity of the assembled unit. The pump shall be run, voltage and current monitored, and checked for noise or other malfunction. Certified performance testing is available upon request.

APPLICATIONS

- Municipal Engineered Lift Stations
- Storm Water Removal
- Wastewater Transfer
- Industrial Wastewater
- Treatment Plants

MATERIAL FEATURES PUMP:

- Grinder - High Head or High Volume
- Discharge - Horizontal, 3" 150# ANSI
- Seals - Dual Mechanical with Viton Elastomers, Upper (Inner) - Graphite Impregnated Carbon on Silicon Carbide; Lower (Outer) - Silicon Carbide on Silicon Carbide
- Construction - Cast Iron ASTM A48, Class 30, 30,000# Tensile Strength, Protected with a Corrosion-Resistant Baked-on Epoxy Powder Coating
- Hardware - 316 Stainless Steel
- O-ring Seals - Buna-N
- Stainless Steel Impeller - Precision Balanced
- Hardened 440 Stainless Steel Cutter and Cutter Plate
- Cuts per minute - over 400,000
- Thermal Sensors and Moisture Detection System
- Optional:
 - Heavy-duty Quick-connect Power and Control Cords
 - Cord Length Options - 10.7, 15.2, 30.5 m [35, 50, 100 ft]
 - Trimmed Impeller
 - Tungsten Carbide on Tungsten Carbide Lower Seal

MOTOR:

- 3-Phase - 200/230, 380/400/415 Volt, 2875 RPM
- Inverter Duty, Class H Insulation, NEMA A Design
- Oil-filled Motor Housing
- Cast Iron Housing with **MidTherm™ Cooling** deep sump design for Improved Heat Dissipation
- Continuous Duty Operation
- Bearings
 - Upper - Single Row Deep Groove Radial Contact
 - Lower - Double Row Angular Contact

LIMITED WARRANTY

Liberty Pumps, Inc. warrants that pumps of its Engineered Product line are free from all factory defects in material and workmanship for a period of 18 months from the date of installation or 24 months from the date of manufacture, whichever occurs first, and provided that such products are used in compliance with their intended applications as set forth in the Liberty Engineered Products specifications and technical manuals. The date of installation shall be determined by a completed pump start-up report and warranty registration form.

A pump startup report, filled out by a qualified installer, is required for warranty to take effect. The report must be submitted within 30 days from the installation date and submitted through the Liberty Pumps website. During the warranty period, the manufacturer's obligation, and at its discretion, shall be limited to the repair or replacement of any parts found by the manufacturer to be defective, provided the product is returned freight prepaid to the manufacturer or its authorized service center, and provided that none of the following warranty-voiding characteristics are evident:

The manufacturer shall not be liable under this Warranty if the product has not been properly installed or maintained in accordance with the printed instructions provided; if it has been disassembled, modified, abused or tampered with; if the pump discharge has been reduced in size; if the pump has been used in water temperatures above those shown in the specifications; if the thermal overload(s) and seal moisture probe(s) have not been properly connected (where equipped); if the pump has been used in water containing sand, lime, cement, gravel or other abrasives; if the product has been used to pump chemicals or hydrocarbons; if the product has been moved from its original installation location, or if the label bearing the serial and code number has been removed.

Liberty Pumps, Inc. shall not be liable for any loss, damage or expenses resulting from installation or use of its products, or for consequential damages, including field labor costs, travel expenses, rental equipment, costs of removal, reinstallation or transportation to and from the factory or an authorized Liberty Pumps repair facility.

There is no other express warranty. All implied warranties, including those of merchantability and fitness for a particular purpose, are limited to 18 months from the date of installation or 24 months from the manufacturing date. This Warranty contains the exclusive remedy of the purchaser, and, where permitted, liability for consequential or incidental damages under any and all warranties are excluded.